

## FR10-33 Flow Regulator, Pressure Compensated

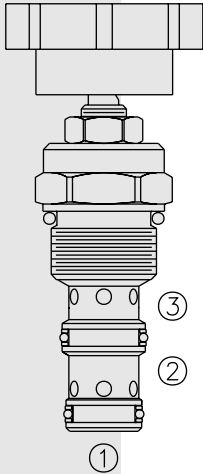

### DESCRIPTION

A screw-in, cartridge-style, adjustable orifice, pressure-compensated, manually-operated, bypass-type hydraulic flow regulating valve. It can be used as a priority-type flow regulator or a restrictive-type 2-way flow regulator when the bypass port (port ②) is blocked.

### OPERATION

The **FR10-33** maintains a constant flow rate from ③ regardless of load pressure changes in the system downstream of ③, or in the bypass leg at ②. Reverse flow (③ to ①) bypasses the control orifice.

The regulated flow increases from closed to fully open, with counter-clockwise rotation of the knob.

**Note:** When used as a bypass flow control in applications where the priority flow port will be blocked by external valving, bypass pressure drop will increase unless a small amount of leakage is provided for the priority port. Consult factory.

### FEATURES

- Bypass port ② may be fully pressurized.
- Fine low-torque adjustment.
- Hardened steel parts for long life.
- Quiet, modulated response.
- Industry common cavity.

### SYMBOLS

#### USASI/ISO:

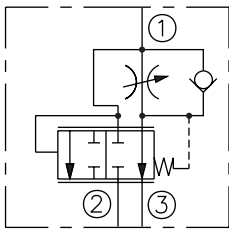

#### 2-Ported:

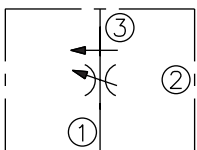

#### 3-Ported:

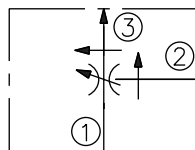

### RATINGS

**Operating Pressure:** 240 bar (3500 psi)

**Flow Rate:** 3-ported regulated flow: 0–13 lpm (0–3.5 gpm)  
2-ported regulated flow: 0–12 lpm (0–3.2 gpm)

**Note:** For higher flow rates, see the FR10-39 valve (page 5.382.1)

**Input Flow:** 3-ported: 0–19 lpm (0–5 gpm) nominal; 0–26 lpm (0–7 gpm) max.

**Internal Leakage:** 33 cc/minute (2 cu. in./minute) at 207 bar (3000 psi)

**Adjustment Torque Required:** 1.7 Nm (15 inch-pounds) at 207 bar (3000 psi)

**Temperature:** -40 to 120°C

**Filtration:** See page 9.010.1

**Fluids:** Mineral-based or synthetics with lubricating properties at viscosities of 7.4 to 420 cSt (50 to 2000 ssu)

**Installation:** No restrictions; See page 9.020.1

**Cavity:** VC10-3; See page 9.110.1

**Cavity Tool:** CT10-3XX; See page 8.600.1

**Seal Kit:** SK10-3X-MM; See page 8.650.1

**Knob Kit:** Part Number 6113160

### PERFORMANCE (Cartridge Only)

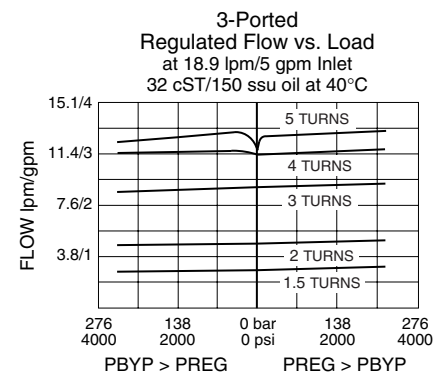
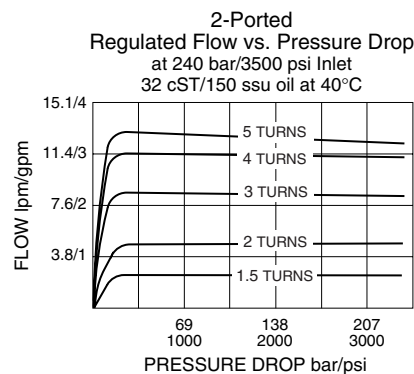
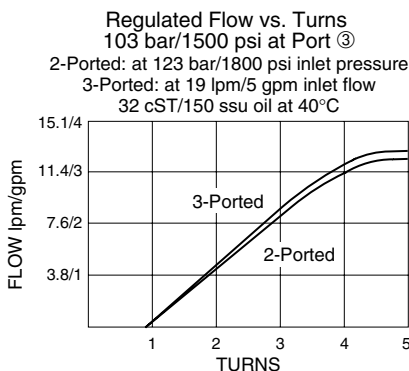

**DIMENSIONS**

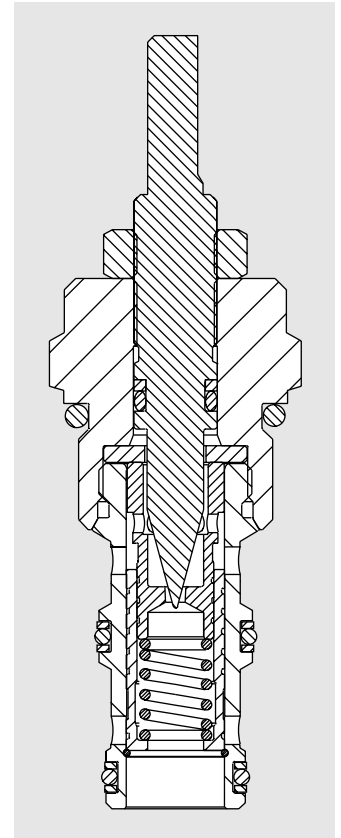
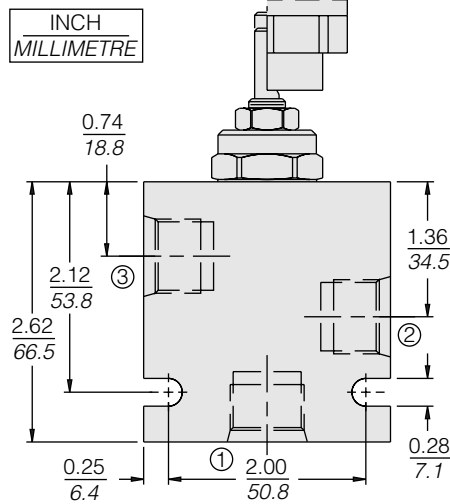
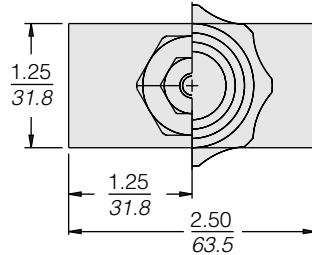
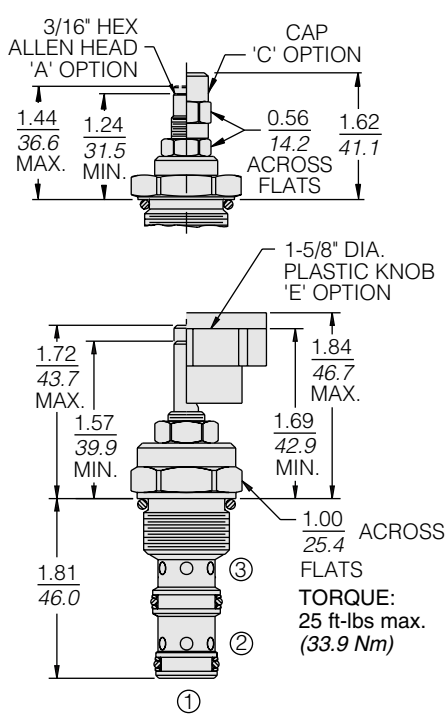

**MATERIALS**

**Cartridge:** Weight: 0.30 kg. (0.68 lbs.); Steel with hardened work surfaces. Zinc-plated exposed surfaces. Buna N O-rings and polyester elastomer back-ups standard.

**Standard Ported Body:** Weight: 0.36 kg. (0.80 lbs.); Anodized high-strength 6061 T6 aluminum alloy, rated to 240 bar (3500 psi); see page 8.010.1. Ductile iron and steel bodies available; consult factory.

**TO ORDER**

